



MANUAL
*FOR ASSEMBLY AND OPERATION OF ELECTRIC FLOW-THROUGH BOILER WITH
RELAY CONTROL*

PASSPORT
OF ELECTRIC BOILER WITH RELAY CONTROL ECOTERMAL
MR 6, 8, 10, 12, 15, 22, 30 kW MX 37, 45, 52, 60 KW
MODULE 6, 8, 10, 12, 15, 22, 30, 37, 45, 52, 60 KW

Bourgas 8000, 47 Slivnitsa Str
tel: 056/814 681; 056/814 215
E – mail: sales@ecotermal-bg.com
www.ecotermal-bg.com

Dear clients! „ECOTERMAL” Ltd. is thanking you for the good choice you made! Please get familiar in detail with the present manual in order to use the full scale of the advantages of the electric boilers with relay control that will secure for you comfortable, ecologic and economic heating through their quality, reliable and modern automation.

CONTENTS:	Page
1. Recommendations	3
2. Introduction	3
3. Technical description of the boiler	4
4. System control	4
5. Operation manual	4
6. Connection to the electric network	5
7. Commissioning	5
8. Conditions of commissioning and undertaking guarantee maintenance	5
9. Diagrams and tables	6-15
9.1 Method of connecting of story (local) heating, Fig. 1	6
9.2 Method of connecting the system to a solid fuel boiler, Fig. 2	6
9.3 Structure of the electric boiler from 6 to 30 kW, Fig. 3	7
9.4 Structure of the electric boiler from 37 to 60 kW, Fig. 4	8
9.5 Structure of the electric module from 6 to 30 kW, Fig. 5	9
9.6 Structure of the electric module from 37 to 60 kW, Fig. 6	10
9.7 Control panel from 6 to 60 kW, Fig. 7	11
9.8 System control from 6 to 60 kW, Fig. 8	12
9.9 Technological distances for boiler/module from 6 to 30 kW, Fig. 9	13
9.10 Technological distances for boiler/module from 37 to 60 kW, Fig. 10	13
9.11 Dimensions of the electric boilers, Tab. 1	14
9.12 Technical characteristics, Tab. 2	14
9.13 Technical data, Tab. 3	14
9.14 Cross-section of power supply cables and automatic breakers, Tab. 4	14
9.15 Weight of the boilers' models, Tab. 5	15
9.16 Equipment of the boilers' models, Tab. 6	15
10. Warranty card	16

1. RECOMMENDATIONS

- This Electrical Boiler is not intended for use by persons (including children) with reduced physical, sensory or mental capabilities, or lack of experience and knowledge, unless they have been given supervision or instruction concerning use of the Electrical Boiler by a person responsible for their safety.
- Children should be supervised to ensure that they do not play with the Electrical boiler.
- It is necessary one to be familiar and to observe the safety operation and assembly manual.
- Electrical boiler has IP 20 protection degree, which applies after an installation at place where it will used.
- After unpacking the boiler, check delivery integrity and equipment..
- Check whether the boiler type corresponds to your needs.
- It is recommendable for each assembly a project to be drafted.
- The assembly may be carried out only by and expert authorized for such activity.
- Boiler assembly should meet the effective prescriptions, norms and to the present manual.
- Connection of the boiler to the power network (if necessary) should be harmonized with the local power supplier, which should be done by the consumer prior to the purchase of the boiler.
- Adjustment and commissioning should be carried out only by a service technician approved by the producer.
- Upon incorrect assembly, damages may occur and the producer shall not be liable thereof.
- In case of failure contact the service organization. Unprofessional intervention may damage the boiler.
- For correct functioning, safety and long-term operation secure prophylactics at least once a year.
- In case of damages incurred by unprofessional assembly, as well as upon noncompliance with the regulations and the operation manual, the producer is not liable and shall not provide guarantee service.
- The heating installation should have air bleeds at all necessary places.
- It is not allowed to make any changes whatsoever on the electrical diagram of the product, except for connection of the indoor temperature controller, the equithermal controller or at telephone control.
- Hydraulic and warm tests should be carried out of each heating installation upon commissioning.
- The electric boiler may operate at open system up to temperature of 95°C max and at closed system up to 110°C at pressure of 1.8 bar in a self-contained heating circuit.
- The assembly organization is obliged to get the client familiar with the operational rules of the heating system as a whole.

2. INTRODUCTION

The flow-through electric boiler ECOTERMAL is a modern ecological source of heat designated for story and central heating of small and average size houses and production facilities. The main advantages of heating with electric power are mostly cost effectiveness, high efficiency, environmental friendliness and compactness. Electric boiler can be used in every system of central or story (local) heating in a direct, accumulating or hybrid system. It can be integrated also in existing heating systems, in parallel with solid fuel boiler (exemplary diagrams are shown on Fig. 1 and 2, page 6). It is recommended for safer operation the electric boilers to be mounted in systems operating with a pump securing enforced circulation of the heat medium.

3. TECHNICAL DESCRIPTION OF THE BOILER

- ▶ Structure of the electric boiler/ module, see Fig. 3 page 7, Fig. 4 page 8, Fig. 5 page 9, Fig. 6 page 10.
- ▶ Equipment of the boilers' models is shown in Tab. 6 page 15.
- ▶ Technical data and technical characteristics of the electric boiler/module, see Tab. 1, 2, 3 and Tab. 4 page 14, and Tab 5 page 15.

4. PRINCIPLE OF OPERATION

The control system performs its functions by effecting on two of the components of the water heating: the heaters and the circulation pump

There are two main operating modes:

- Boiler Temperature Control Operating Mode

Each electrical boiler/module contains temperature controller. The temperature set-point value can be adjusted between 30°C and 90°C. Upon reach of the setpoint, the temperature controller switches off the heaters. When the temperature of the boiler's water goes below the set point, the heaters are switched back on. The temperature overheat protection is provided by a blocking /emergency/ thermostat. If there is a temperature rise up to 105° C, caused by any reason, the blocking thermostat turns off the heaters and ALARM message is displayed. The thermostat must be switched back to normal operating mode only by authorized service engineer, who has to provide detection and removal of the fault causing the thermostat switch off.

- Room Temperature Control Operating Mode

The room temperature controller is installed in the premise where you need the temperature to be precisely controlled. The control unit is installed in the boiler. When the set room temperature is above the current temperature of the premise, the heater and the circulating pump are switched on. Upon reach of the set room temperature, the controller switches off the heater and the pump. The power of the boiler is calculated such that at the lowest environment temperature for the region it could provide room temperature of 25° C.

Number of comutation:

- ▶ 6 to 60 kW - two-levels

This principle of control does not allow major amplitude in water temperature in the boiler body in the established mode of work.

Models from 6 to 60 kW can bind to the ON / OFF room thermo regulator (see Fig.8 page12).

5. OPERATION MANUAL

- The customer has to provide water supply and electricity to the installation.
- The customer monitors for leaks and controls the operating pressure in the system.
- Adjust the boiler or room temperature depending on the operating principle of the installation and personal preferences.
- Upon departure from the parameters calls to authorized service.

- The service is performed by specialists familiar with the structure, management and operation of the device.
- When the electric power stops and restores again, the electric boiler automatically starts again.

6. CONNECTING TO THE ELECTRIC NETWORK

- Connecting the electric switchboard to the power supply network and the boiler electric installation assembly should be carried out only by an expert with the necessary qualification. The power supply is connected through not severable joint according to the connection diagram. The cross-section of the power supply cable should be selected in accordance with the boiler power (see table 4 page 14).

7. COMMISSIONING

Boiler's startup is possible after performed control on the good working order of:

- the connections to the heating system,
- checking of the system pressure,
- checking of the electrical connections,
- checking whether the valves and taps of the heating system are opened,
- switch on the automatic fuse of the electric boiler,
- preset the desired temperature of the boiler and the room thermo regulator.

Servicing of the room thermo regulator is done according to the instructions thereto.

The heating systems may be filled in only by water or mixture of water and antifreeze.

8. CONDITIONS OF COMMISSIONING AND UNDERTAKING GUARANTEE MAINTENANCE – GENERAL TERMS:

The electrical boiler/module is mounted with the help of consoles only on a wall that can bear its weight. The boiler location should be selected in a manner to secure access – technological tolerance from its all four sides is shown on Fig. 9 and 10 at page 13.

1. The boiler/module should be mounted at a place suitable for servicing (free access thereto) and possibility of opening the front lid.
2. The boiler/module should be mounted suspended on the wall at minimum height of 1 m of the floor.
3. Water filter should be mounted at the cold water intake before the pump by observing the direction marked on the filter itself (boiler fixture), in accordance with the attached manufacturer's instructions.
4. The boiler/module should not be contaminated with building materials.
5. Fitting connections should be mounted on the boiler/module intake and the outlet.
6. Hydraulic test should be carried out at an index of 1.25 above the operating pressure.
7. Upon assembly, it is necessary the adjustments of the boiler and the blocking thermostats to be checked up. The actual control is done during the warm test.
8. The guarantee shall be effective as from the commissioning date, but not later than six months as from the date of the purchase.

Method of connecting of story (local) heating

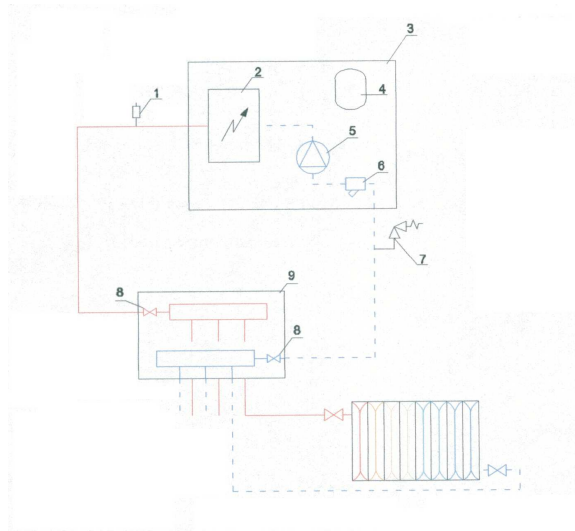

- | | |
|---------------------|-------------------|
| 1. Air bleeder | 7. Safety valve |
| 2. Electric heater | 8. Shut off valve |
| 3. Electric boiler | 9. Manifold Box |
| 4. Expansion tank | |
| 5. Circulation pump | |
| 6. Water filter | |

Fig. 1

Method of connecting the system to a solid fuel boiler

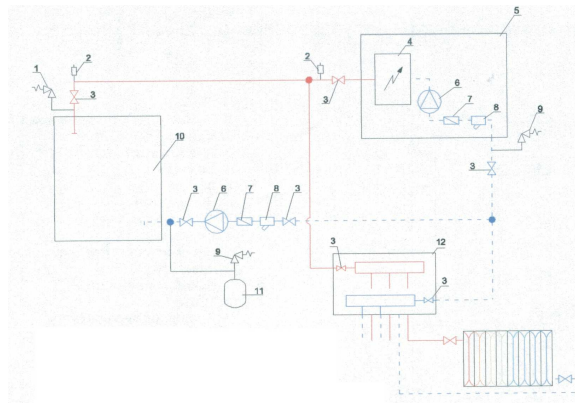

- | | |
|--------------------------------|-----------------------------|
| 1. Safety valve by temperature | 7. Return valve |
| 2. Air bleeder | 8. Water filter |
| 3. Shut off valve | 9. Safety valve by pressure |
| 4. Electric heater | 10. Solid fuel boiler |
| 5. Electric boiler | 11. Expansion tank |
| 6. Circulation pump | 12. Manifold Box |

Fig. 2

ELECTRICAL BOILER MR 6 ÷ 30 kW

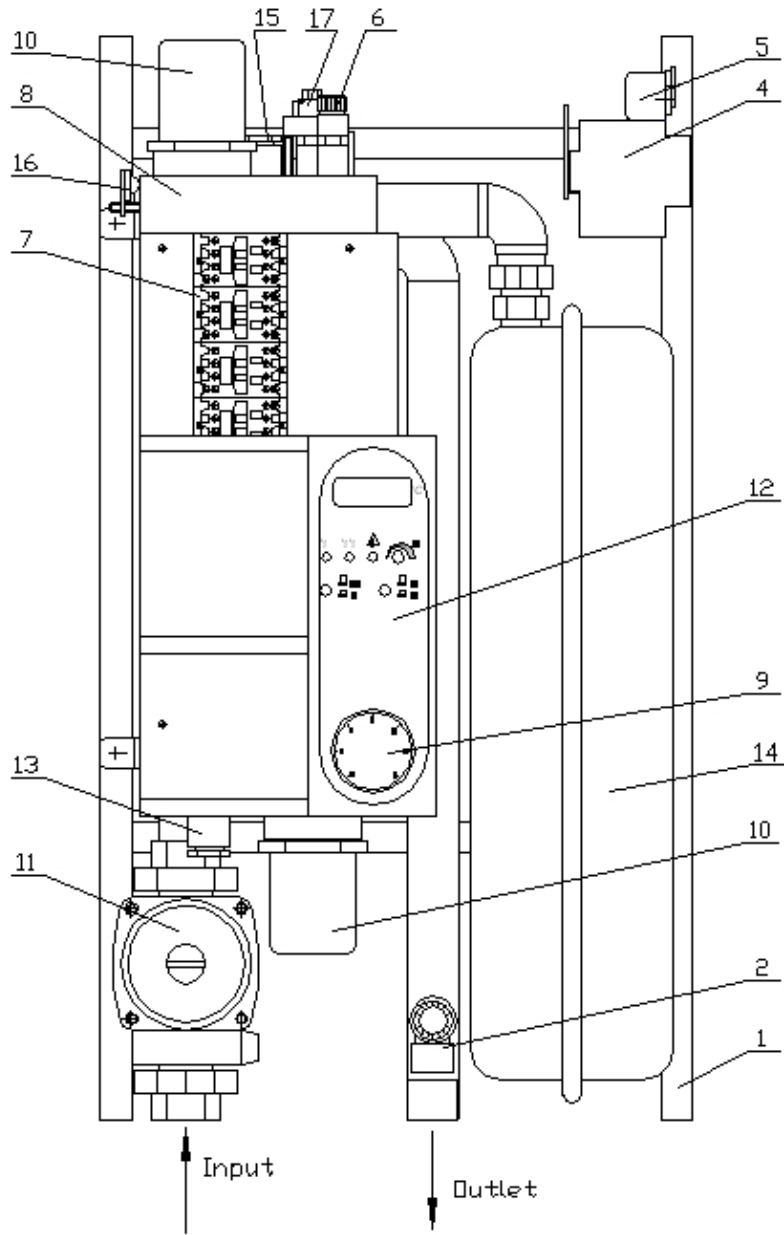

Fig. 3

- | | |
|------------------------------------------------------------------------------------------------------------------------------------------------------------------------------------------------------------------------------------------------------------------------------------------------------------------------------------|--------------------------------------------------------------------------------------------------------------------------------------------------------------------------------------------------------------------------------------------------------------------------------------|
| <ul style="list-style-type: none"> 1. Frame 2. Safety Valve by pressure 2.5 bar 4. Automatic breaker with additional protection 5. Emergency (blocking) thermostat 6. Air bleeder 7. System control –contactors 8. Water Container 9. Pressure-gauge | <ul style="list-style-type: none"> 10. Heaters 11. Circulation Pump 12. Control Panel 13. Pressure-gauge Valve 14. Expansion Tank 15. Thermostat Pocket 16. Thermostat -bimetallic 17. Pressure switch |
|------------------------------------------------------------------------------------------------------------------------------------------------------------------------------------------------------------------------------------------------------------------------------------------------------------------------------------|--------------------------------------------------------------------------------------------------------------------------------------------------------------------------------------------------------------------------------------------------------------------------------------|

ELECTRICAL BOILER MX 37 ÷ 60 kW

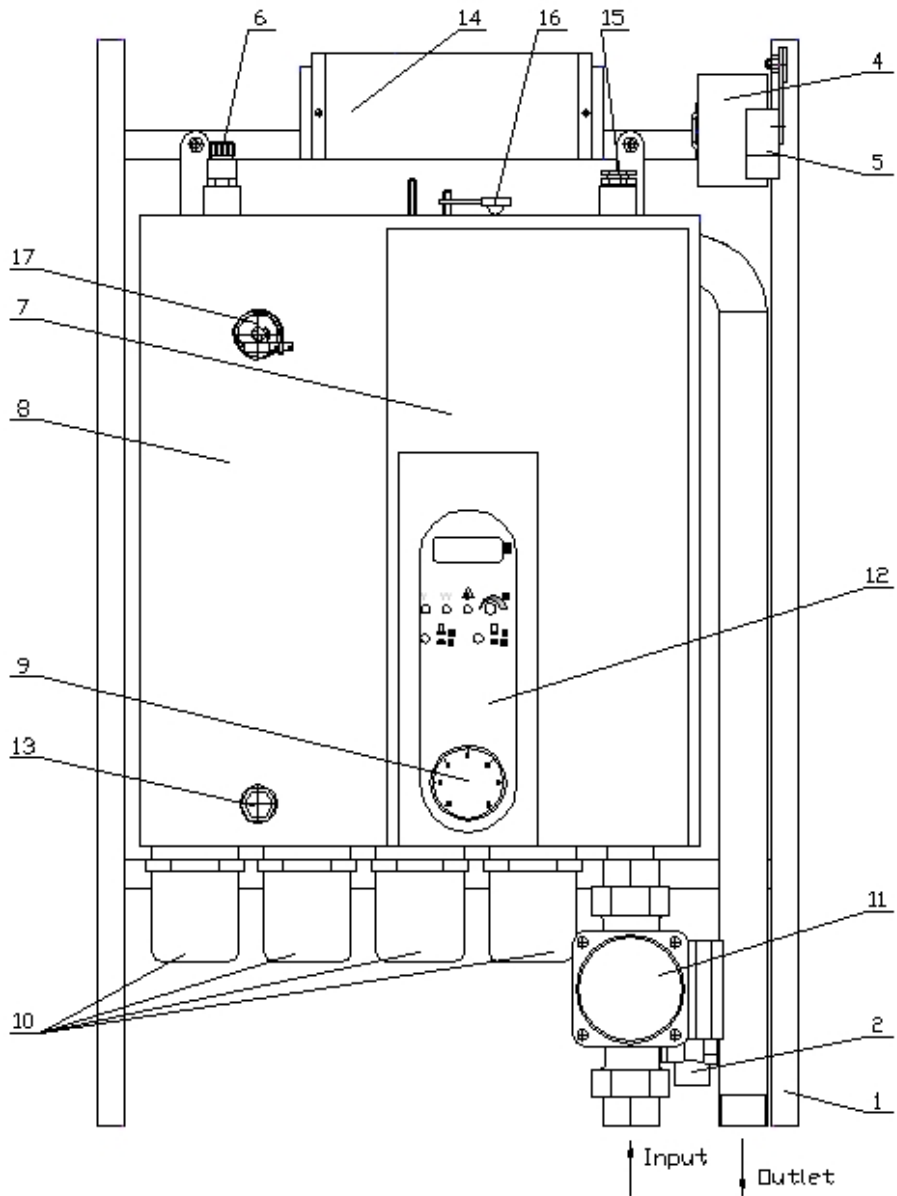

Fig. 4

- | | |
|----------------------------------------------------|----------------------------|
| 1. Frame | 10. Heaters |
| 2. Safety Valve by pressure 2.5 bar | 11. Circulation Pump |
| 4. Automatic breaker
with additional protection | 12. Control Panel |
| 5. Emergency (blocking) thermostat | 13. Pressure-gauge Valve |
| 6. Air bleeder | 14. Power Wires |
| 7. System control –contactors | 15. Thermostat Pocket |
| 8. Water Container | 16. Thermostat -bimetallic |
| 9. Pressure-gauge | 17. Pressure switch |

ELECTRICAL MODULE K 6 ÷ 30 kW

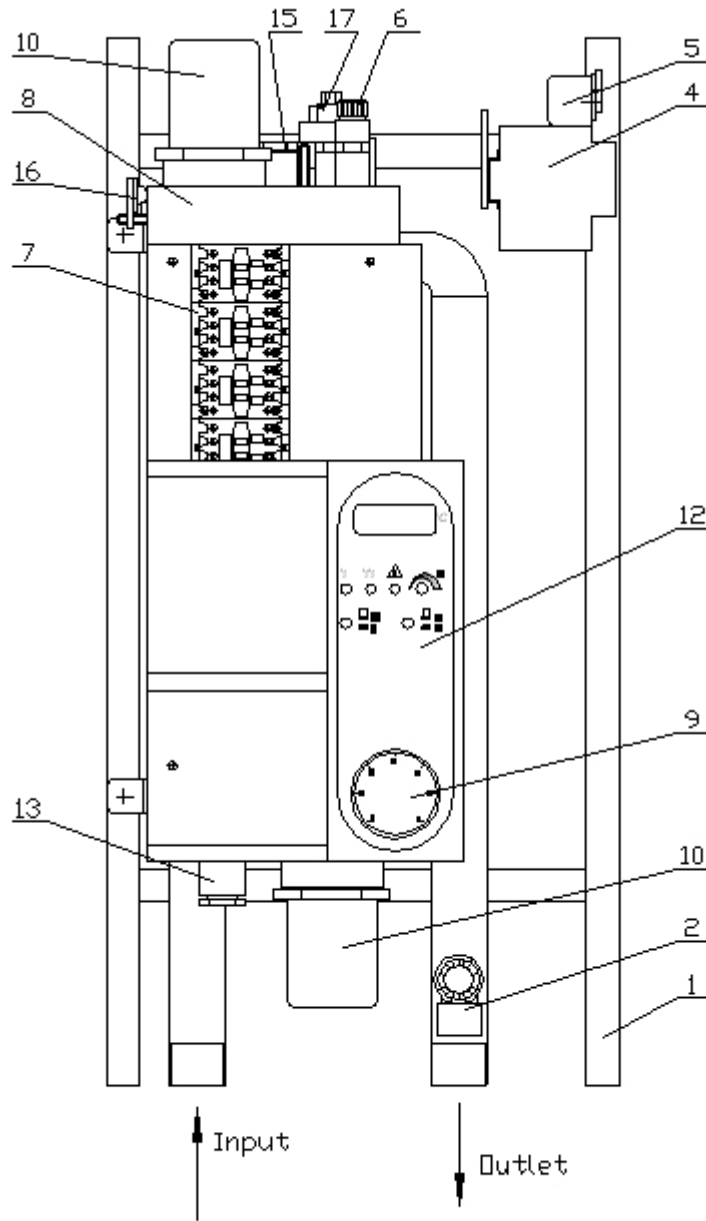

Fig. 5

- | | |
|-------------------------------------------------------------------------------------------------------------------------------------------------------------------------------------------------------------------------------------------------------------------------------------------------------------|-------------------------------------------------------------------------------------------------------------------------------------------------------------------------------------------------------------------------------------------------------|
| <ul style="list-style-type: none"> 1. Frame 2. Safety Valve by pressure 2.5 bar 4. Automatic breaker
with additional protection 5. Emergency (blocking) thermostat 6. Air bleeder 7. System control –contactors 8. Water Container | <ul style="list-style-type: none"> 9. Pressure-gauge 10. Heaters 12. Control Panel 13. Pressure-gauge Valve 15. Thermostat Pocket 16. Thermostat -bimetallic 17. Pressure switch |
|-------------------------------------------------------------------------------------------------------------------------------------------------------------------------------------------------------------------------------------------------------------------------------------------------------------|-------------------------------------------------------------------------------------------------------------------------------------------------------------------------------------------------------------------------------------------------------|

MODULE K 37 ÷ 60 kW

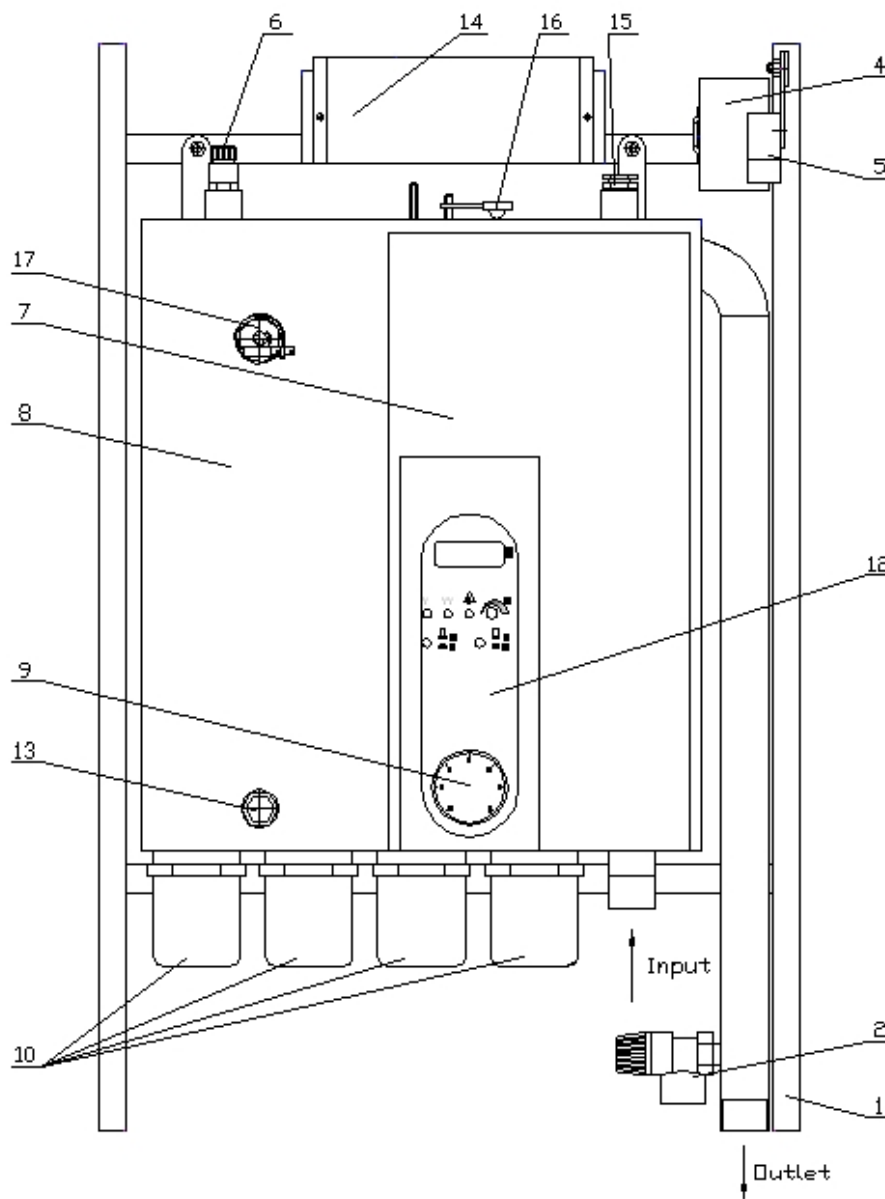

Fig. 6

- | | |
|----------------------------------------------------|----------------------------|
| 1. Frame | 9. Pressure-gauge |
| 2. Safety Valve by pressure 2.5 bar | 10. Heaters |
| 4. Automatic breaker
with additional protection | 12. Control Panel |
| 5. Emergency (blocking) thermostat | 13. Pressure-gauge Valve |
| 6. Air bleeder | 14. Power Wires |
| 7. System control –contactors | 15. Thermostat Pocket |
| 8. Water Container | 16. Thermostat -bimetallic |
| | 17. Pressure switch |

CONTROL PANEL 6 ÷ 60 kW

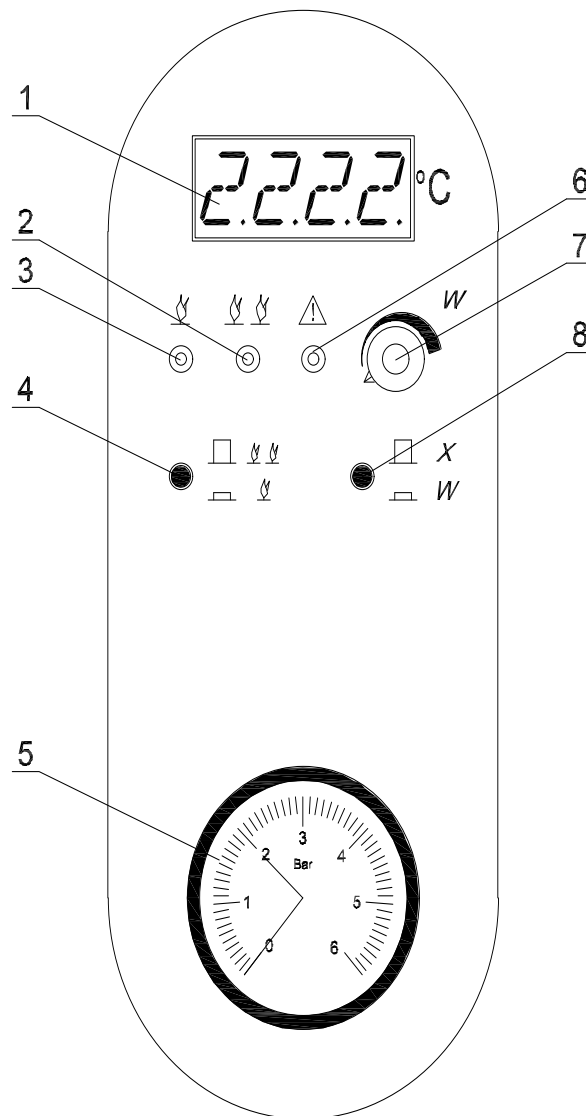

Fig.7

1. Digital Display
2. Green LED Indication– Second Stage ON
3. Green LED Indication– First Stage ON
4. Button - First Stage OFF (when it is pressed)
5. Pressure-gauge
6. LED Indication of activated emergency thermostat
7. Potentiometer of boiler's temperature
8. Button – set/current temperature

SYSTEM CONTROL 6 ÷ 60 kW

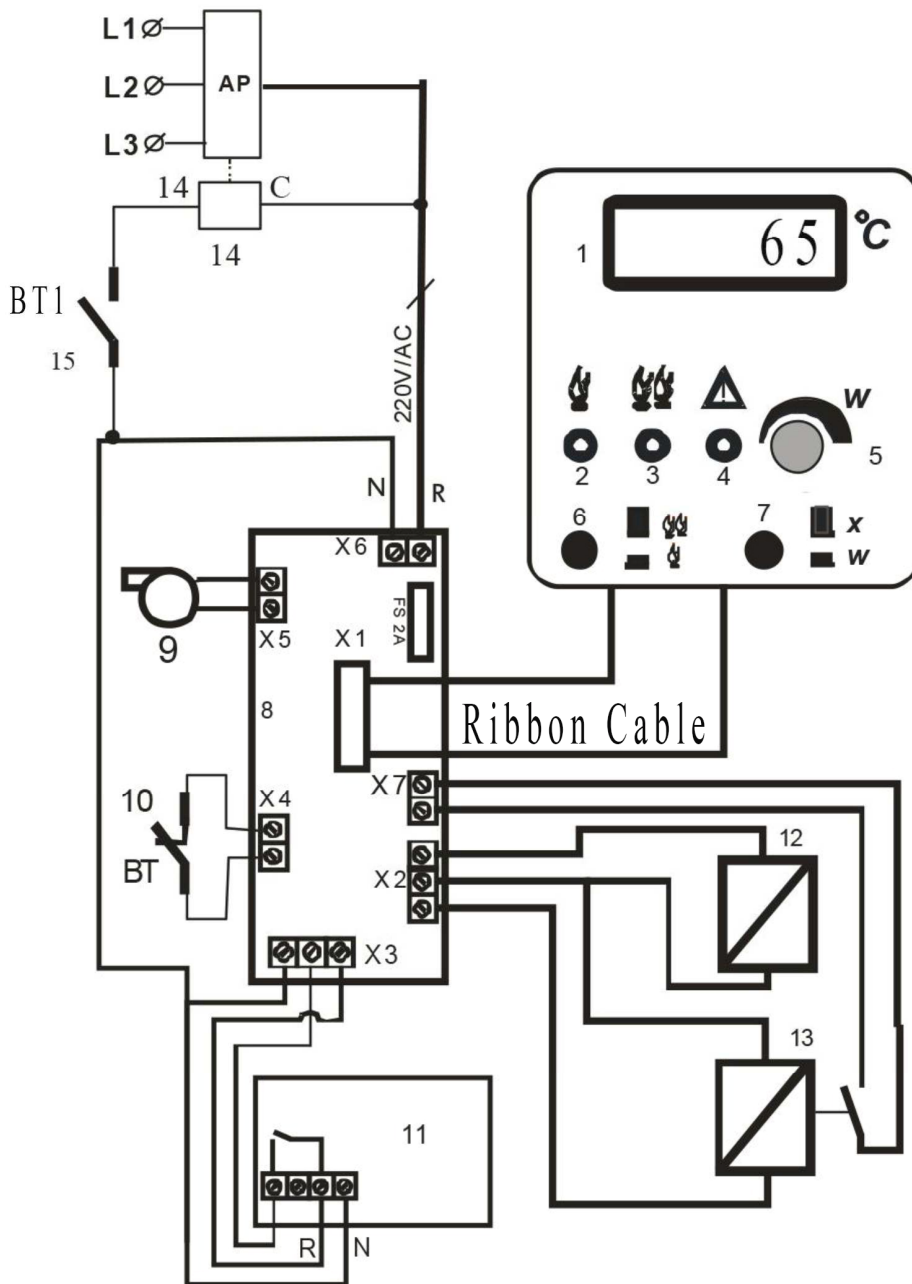

Fig. 8

To power wire X6 is getting operational power 240V/50Hz. It is secured by built-in breaker FS - 2A. X2 is connected to the management of the relays. X4 is connected to the block (emergency) thermostat. X5 is connected to the circulation pump. X7 is connected to normally open contact of the first relay. X1 is connected by ribbon cable to the control panel. Boiler temperature sensor is connected to X2 (control panel). The sensor is polar, you must follow the indicated polarity when connected it. In a reverse connection does not fail, but the temperature is unreal. X3 is connected to the ON / OFF room thermo regulator.

Boiler/Module 6+30 kW

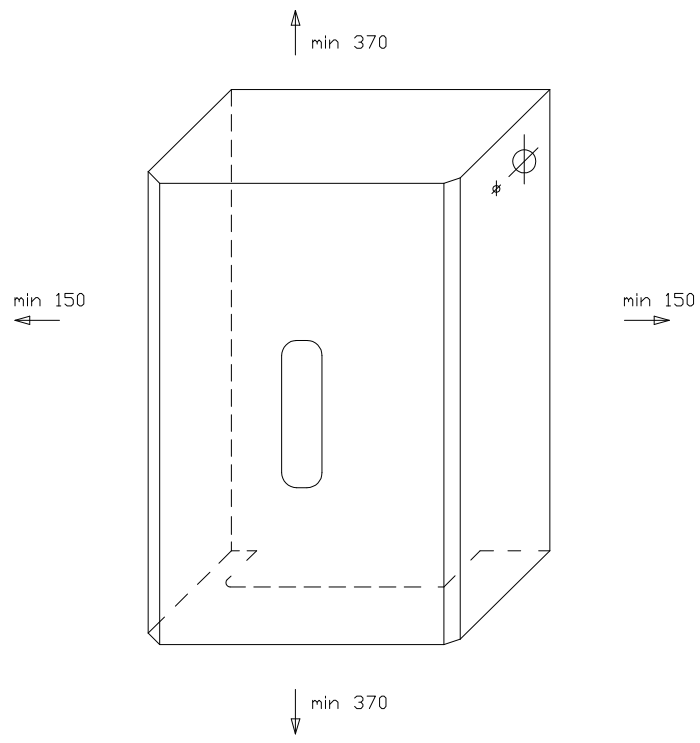

Fig. 9

Boiler/Module 37÷60 kW

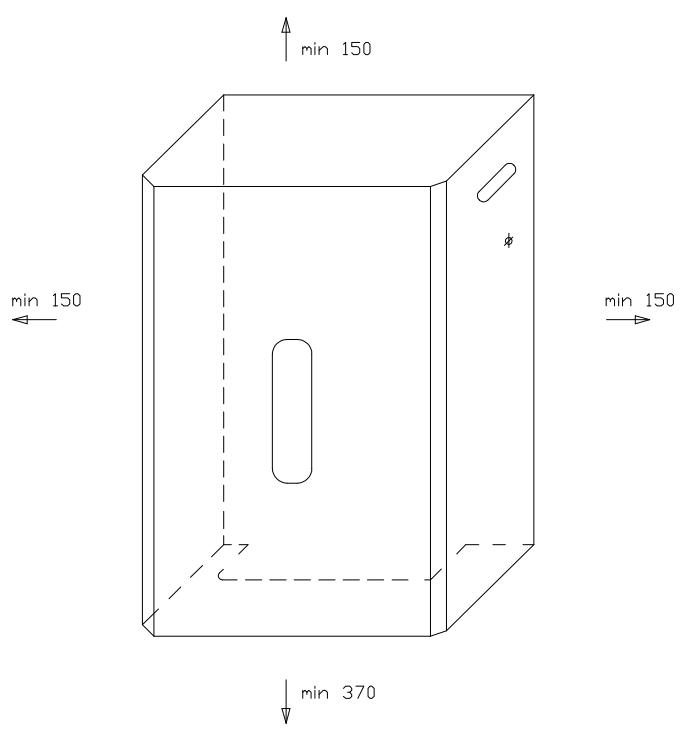

Fig. 10

Dimensions of electric boilers/modules with relay control

MR 6 - 30		kW	6 - 30
height		mm	700
length		mm	385
width		mm	280
Module K 6 – 30		kW	6 - 30
height		mm	645
length		mm	315
width		mm	280
MX / Module 37 - 60		kW	37 - 60
height		mm	780
length		mm	500
width		mm	295

Tab. 1

Technical characteristics of electrical boilers/modules with relay control

Maximum power	kW	6,8	10,12	15	22,30	37, 45	52, 60
Commutations level	pcs	2	2	2	2	2	2
Boiler body volume	dm ³	8,9	8,9	8,9	8,9	26	26
Supply voltage	V	240/400	240/400	400	400	400	400

Tab. 2

Technical data of electric boilers/modules with relay control

Maximum operating pressure	Bar	2,5
Test pressure	Bar	4,0
Regulation of heat medium temperature	°C	30–90
Room temperature control	°C	5–30
Connection pipes dimensions 6 – 60 kW	G	1”
Efficiency index	%	99,30

Tab. 3

Cross-section of power supply cables to electric network

P [kW]	I_{heater} [A]	Cross-section [mm²]	I_{breaker} [A]
6	8,7	5 x 2,5	10
8	11,6	5 x 2,5	16
10	14,5	(3 x 2,5 + 1,5) + 1 x 4	20
12	17,4	(3 x 4 + 2,5) + 1 x 4	25
15	21,8	(3 x 4 + 2,5) + 1 x 6	32
22	31,25	(3 x 6 + 4) + 1 x 10	50
30	43,5	(3 x 10 + 6) + 1 x 10	63
37	53,6	(3 x 10 + 6) + 1 x 16	1 x 50/1 x 32
45	60,9	(3 x 16 + 10) + 1 x 16	1 x 63/1 x 32
52	78,3	(3 x 16 + 10) + 1 x 16	1 x 63/ 1 x 50
60	91	(3 x 25 + 16) + 1 x 25	2 x 63

Tab. 4

Weight of the electrical boiler/module models

Electrical boilers			Electrical modules		
Model	Power, kW	Weight, kg	Model	Power, kW	Weight, kg
6 MR	6	31,0	6 K	6	22,0
8 MR	8		8 K	8	
10 MR	10		10 K	10	
12 MR	12		12 K	12	
15 MR	15	31,5	15 K	15	22,5
22 MR	22	33,0	22 K	22	24,0
30 MR	30	35,0	30 K	30	26,0
37 MX	37	48,0	37 K	37	45,0
45 MX	45	49,0	45 K	45	46,0
52 MX	52	50,0	52 K	52	47,0
60 MX	60	52,0	60 K	60	49,0

Tab. 5

Equipment of the boilers' models

EQUIPMENT	Model		
	MR	MX	Module K 6 – 60 kW
Expansion tank	√	-	-
Circulation pump	√	√	-
Water filter	√	√	-
Safety valve	√	√	√
Emergency (blocking) thermostat	√	√	√
Air bleeder	√	√	√
Mounting brackets	√	√	√

Tab. 6

Note: The manufacturer reserves the right to make construction changing of the product.